

NCK

NOVA HC65

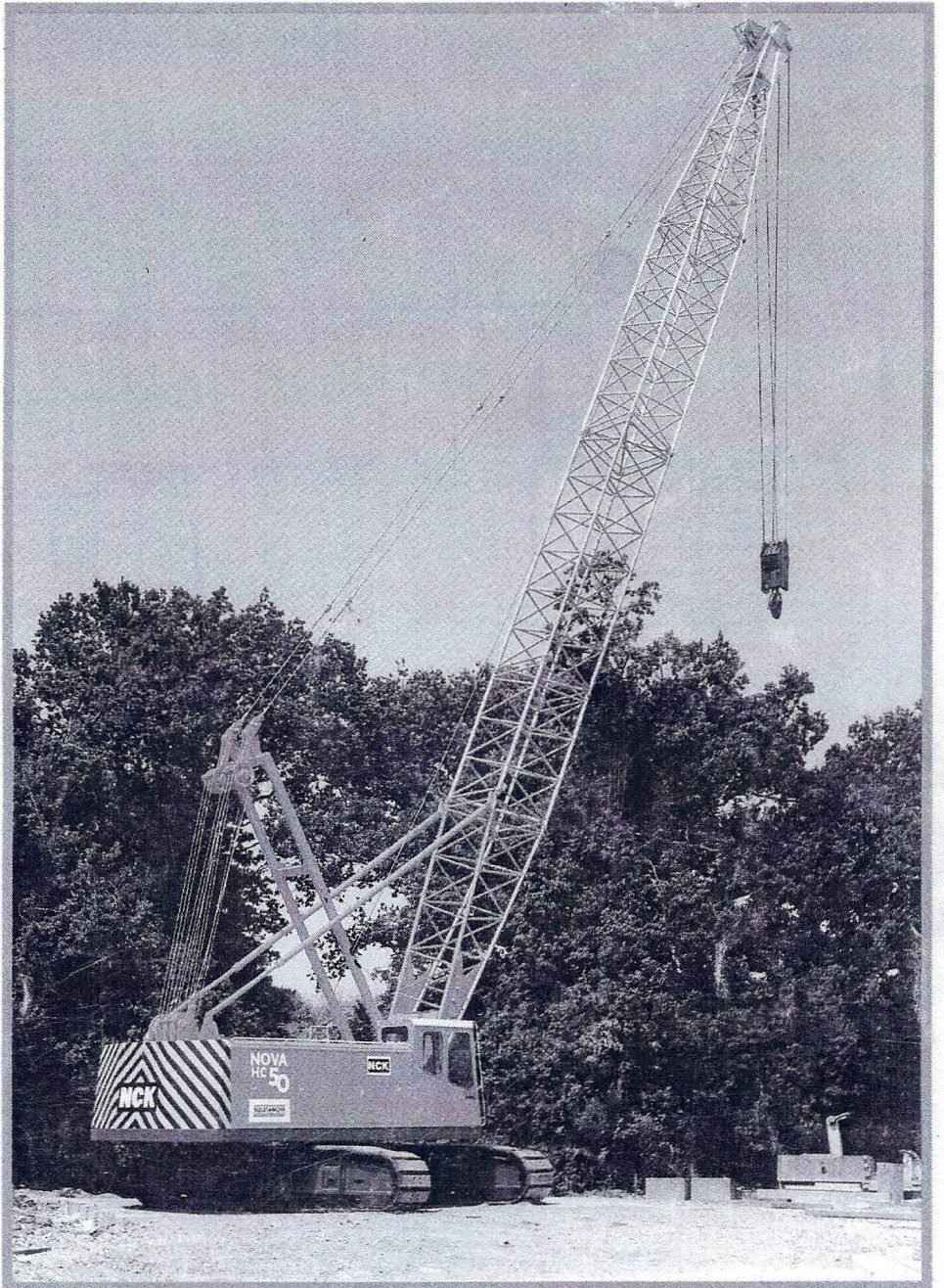

Hydraulic Crawler Crane

DATA

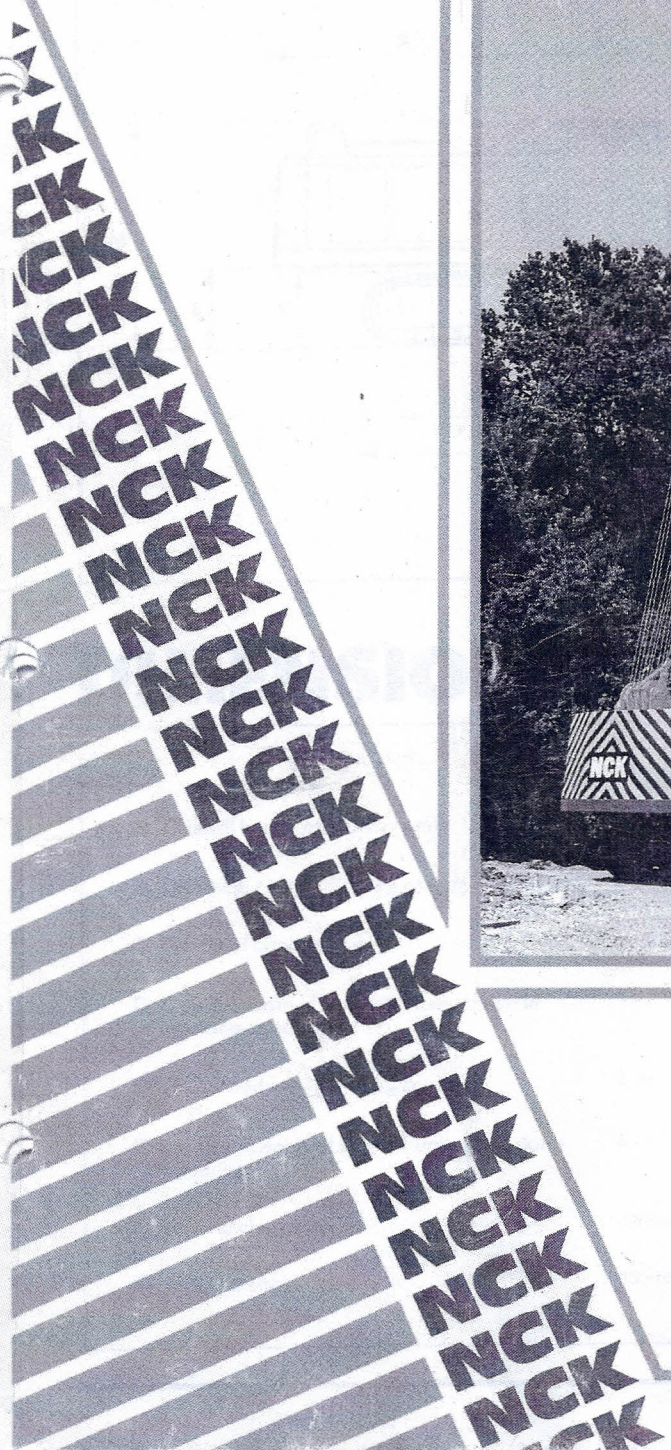

HC65 DATA

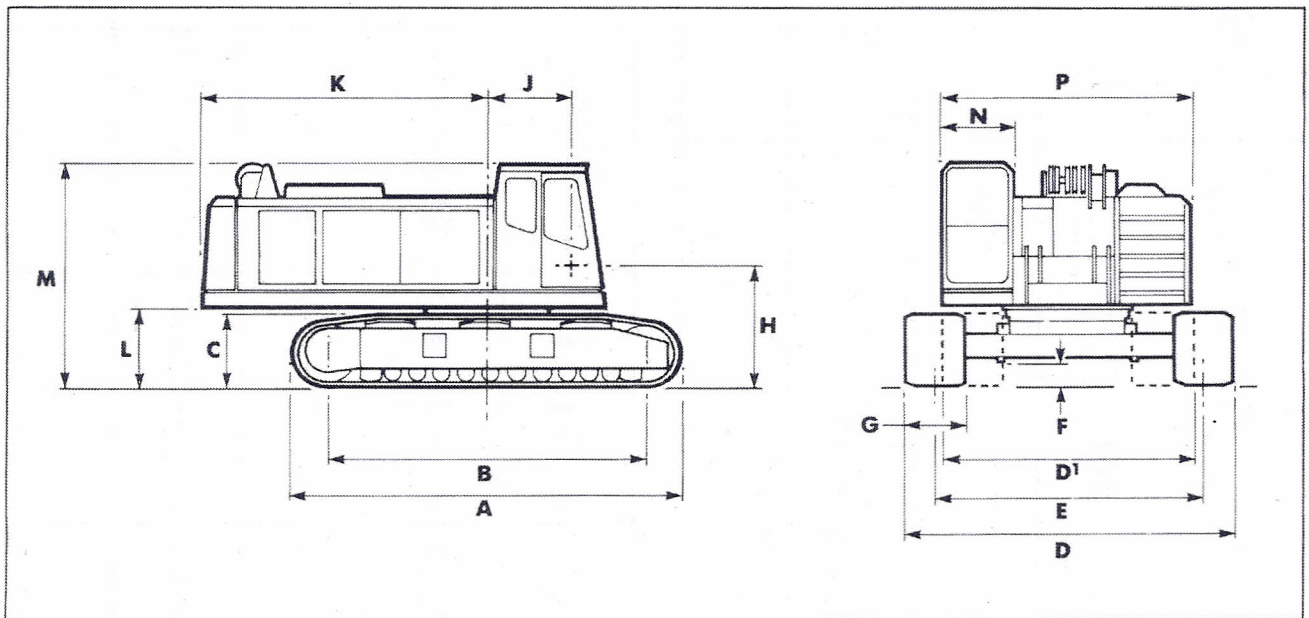

DIMENSIONS

	metres		metres
A Overall length of crawler units	6.03	H Height of boom foot	1.89
B Distance, centre to centre of tumblers	5.00	J Distance centre line rotation to boom foot	1.16
C Height of crawler units	1.13	K Tailradius to rear of counterweight	4.27
D Overall width of crawlers: Extended – in working condition	4.60	L Ground clearance under counterweight	1.295
D¹ Retracted – in travelling condition	3.50	M Overall height of "A" frame sheave, and operators cab in working condition	3.39
E Centre to centre of crawler units in working condition	3.74	N Width of Operators Module	950mm
F Ground clearance	420mm	P Overall width over machinery cab	3.44
G Crawler shoe width	850mm		

HC65 DATA

LIFTING CAPACITIES OFFSET HEAD BOOM MAIN BOOM (with maximum counterweight)

METRIC

Boom length	Radius	Boom angle	GROSS WORKING LOAD	
			BS 1757:1986	75% Rating
m	m	degrees	kg	kg
12.0	3.6	80	65000	65000
	4.0	78	65000	65000
	5.0	73	47900	45000
	6.0	68	35800	33600
	7.0	63	28400	26700
	8.0	57	23500	22100
	9.0	51	20000	18900
	10.0	44	17300	16400
15.0	4.1	80	60400	64000
	5.0	77	47900	45000
	6.0	73	35700	33600
	7.0	68	28400	26700
	8.0	64	23500	22100
	9.0	60	20000	18800
	10.0	55	17300	16300
	12.0	45	13600	12800
18.0	4.6	80	52300	52000
	5.0	79	47900	45000
	6.0	76	35700	33600
	7.0	72	28400	26700
	8.0	69	23400	22100
	9.0	65	19900	18800
	10.0	62	17200	16300
	12.0	54	13500	12800
21.0	5.2	80	44000	42000
	6.0	78	35700	33600
	7.0	75	28300	26700
	8.0	72	23400	22100
	9.0	69	19900	18700
	10.0	66	17200	16200
	12.0	60	13500	12700
	14.0	53	11000	10400
24.0	5.7	80	38600	36400
	6.0	79	35700	33600
	7.0	77	28300	26700
	8.0	74	23400	22000
	9.0	72	19800	18700
	10.0	69	17100	16200
	12.0	64	13400	12700
	14.0	59	10900	10300
27.0	6.2	80	33800	31800
	7.0	78	28200	26600
	8.0	76	23300	22000
	9.0	74	19700	18600
	10.0	72	17100	16100
	12.0	67	13300	12600
	14.0	62	10800	10300
	16.0	57	9000	8600
30.0	6.7	80	30100	28300
	7.0	79	28200	26600
	8.0	78	23200	21900
	9.0	76	19700	18600
	10.0	74	17000	16100
	12.0	70	13300	12600
	14.0	65	10800	10200
	16.0	61	9000	8500
33.0	7.2	80	26500	25400
	8.0	79	23100	21800
	9.0	77	19600	18500
	10.0	75	16900	16000
	12.0	71	13200	12500
	14.0	68	10700	10100
	16.0	64	8900	8500
	18.0	60	7500	7200
36.0	8.0	80	22800	21800
	9.0	78	19500	18400
	10.0	76	16800	15900
	12.0	73	13100	12400
	14.0	70	10600	10100
	16.0	66	8800	8400
	18.0	63	7400	7100
	20.0	59	6400	6100
39.0	8.3	80	19800	20600
	9.0	79	19400	18400
	10.0	77	16700	15900
	12.0	74	13000	12300
	14.0	71	10500	10000
	16.0	68	8700	8300
	18.0	65	7300	7000
	20.0	62	6300	6000
42.0	8.6	80	17200	16100
	9.0	79	16700	15600
	10.0	77	14000	13100
	12.0	74	10300	9200
	14.0	71	8500	8100
	16.0	68	7100	6700
	18.0	65	5700	5300
	20.0	62	4700	4300

Boom length	Radius	Boom angle	GROSS WORKING LOAD	
			BS 1757:1986	75% Rating
m	m	degrees	kg	kg
30.0	6.7	80	30100	28300
	7.0	79	28200	26600
	8.0	78	23200	21900
	9.0	76	19700	18600
	10.0	74	17000	16100
	12.0	70	13300	12600
	14.0	65	10800	10200
	16.0	61	9000	8500
	18.0	57	7600	7300
	20.0	52	6600	6300
	22.0	47	5700	5500
	24.0	41	5000	4900
	26.0	35	4500	4300
	28.0	27	4000	3900
33.0	7.2	80	26500	25400
	8.0	79	23100	21800
	9.0	77	19600	18500
	10.0	75	16900	16000
	12.0	71	13200	12500
	14.0	68	10700	10100
	16.0	64	8900	8500
	18.0	60	7500	7200
	20.0	56	6500	6200
	22.0	51	5600	5400
36.0	8.0	80	22800	21800
	9.0	78	19500	18400
	10.0	76	16800	15900
	12.0	73	13100	12400
	14.0	70	10600	10100
	16.0	66	8800	8400
	18.0	63	7400	7100
	20.0	59	6400	6100
	22.0	55	5500	5300
	24.0	51	4800	4700
39.0	8.3	80	19800	20600
	9.0	79	19400	18400
	10.0	77	16700	15900
	12.0	74	13000	12300
	14.0	71	10500	10000
	16.0	68	8700	8300
	18.0	65	7300	7000
	20.0	62	6300	6000
	22.0	58	5400	5300
	24.0	55	4700	4600
42.0	8.6	80	17200	16100
	9.0	79	16700	15600
	10.0	77	14000	13100
	12.0	74	10300	9200
	14.0	71	8500	8100
	16.0	68	7100	6700
	18.0	65	5700	5300
	20.0	62	4700	4300
	22.0	58	3900	3600
	24.0	51	3300	2900
45.0	8.9	80	14600	13500
	9.0	79	14100	13000
	10.0	77	11400	10500
	12.0	74	7700	6600
	14.0	71	6300	5900
	16.0	68	5300	4900
	18.0	65	4300	3900
	20.0	62	3500	3100
	22.0	58	2700	2300
	24.0	51	2100	1700

HC65 DATA

LIFTING CAPACITIES OFFSET HEAD BOOM MAIN BOOM (with maximum counterweight)

METRIC

Boom length	Radius	Boom angle	GROSS WORKING LOAD	
			BS 1757:1986	75% Rating
m	m	degrees	kg	kg
42.0	8.8	80	16700	18900
	9.0	80	16400	18300
	10.0	78	16300	15800
	12.0	76	12900	12300
	14.0	73	10400	10000
	16.0	70	8600	8300
	18.0	67	7300	7000
	20.0	64	6200	6000
	22.0	61	5400	5200
	24.0	58	4700	4600
	26.0	54	4100	4000
	28.0	51	3600	3600
	30.0	47	3200	3200
	32.0	43	2900	2900
	34.0	39	2500	2600
	36.0	34	2300	2300
38.0	29	2000	2100	
40.0	23	1800	1900	
45.0	9.3	80	14500	17400
	10.0	79	14300	15800
	12.0	77	12800	12200
	14.0	74	10300	9900
	16.0	71	8500	8200
	18.0	68	7200	6900
	20.0	66	6100	5900
	22.0	63	5300	5100
	24.0	60	4600	4500
	26.0	57	4000	4000
	28.0	54	3500	3500
	30.0	51	3100	3100
	32.0	47	2800	2800
	34.0	44	2400	2500
	36.0	40	2200	2200
	38.0	35	1900	2000
40.0	31	1700	1800	
48.0	10.0	80	12600	15700
	12.0	77	12100	12100
	14.0	75	10200	9800
	16.0	72	8400	8100
	18.0	70	7100	6800
	20.0	67	6000	5800
	22.0	65	5200	5000
	24.0	62	4500	4400
	26.0	59	3900	3900
	28.0	56	3400	3400
	30.0	53	3000	3000
	32.0	50	2600	2700
	34.0	47	2300	2400
36.0	44	2000	2100	
38.0	40	1800	1900	
40.0	36	1600	1700	

Boom length	Radius	Boom angle	GROSS WORKING LOAD	
			BS 1757:1986	75% Rating
m	m	degrees	kg	kg
51.0	10.4	80	11100	14700
	12.0	78	10700	12000
	14.0	76	10100	9700
	16.0	73	8300	8000
	18.0	71	7000	6700
	20.0	69	5900	5700
	22.0	66	5100	5000
	24.0	64	4400	4300
	26.0	61	3800	3800
	28.0	59	3300	3300
	30.0	56	2900	2900
	32.0	53	2500	2600
	34.0	50	2200	2300
	36.0	47	1900	2000
	38.0	44	1700	1800
	40.0	41	1500	1600
54.0	11.0	80	9700	13500
	12.0	79	9500	12000
	14.0	77	9000	9600
	16.0	74	8200	7900
	18.0	72	6900	6600
	20.0	70	5800	5600
	22.0	68	5000	4900
	24.0	65	4300	4200
	26.0	63	3700	3700
	28.0	61	3200	3200
	30.0	58	2800	2800
	32.0	56	2400	2500
	34.0	53	2100	2200
36.0	50	1800	1900	
38.0	47	1600	1700	
40.0	44	1400	1500	